

CUSTOMER

# CAN ART STD.

DIE No.

EH05926

REV. No.

1

DESCRIPTION

3.000 x 0.120 THK. SQ. TUBE w/ ROUNDED CORNERS

CUSTOMER PART No.

QUOTE No.

09-0169-1

PROPOSAL No.

H-20412

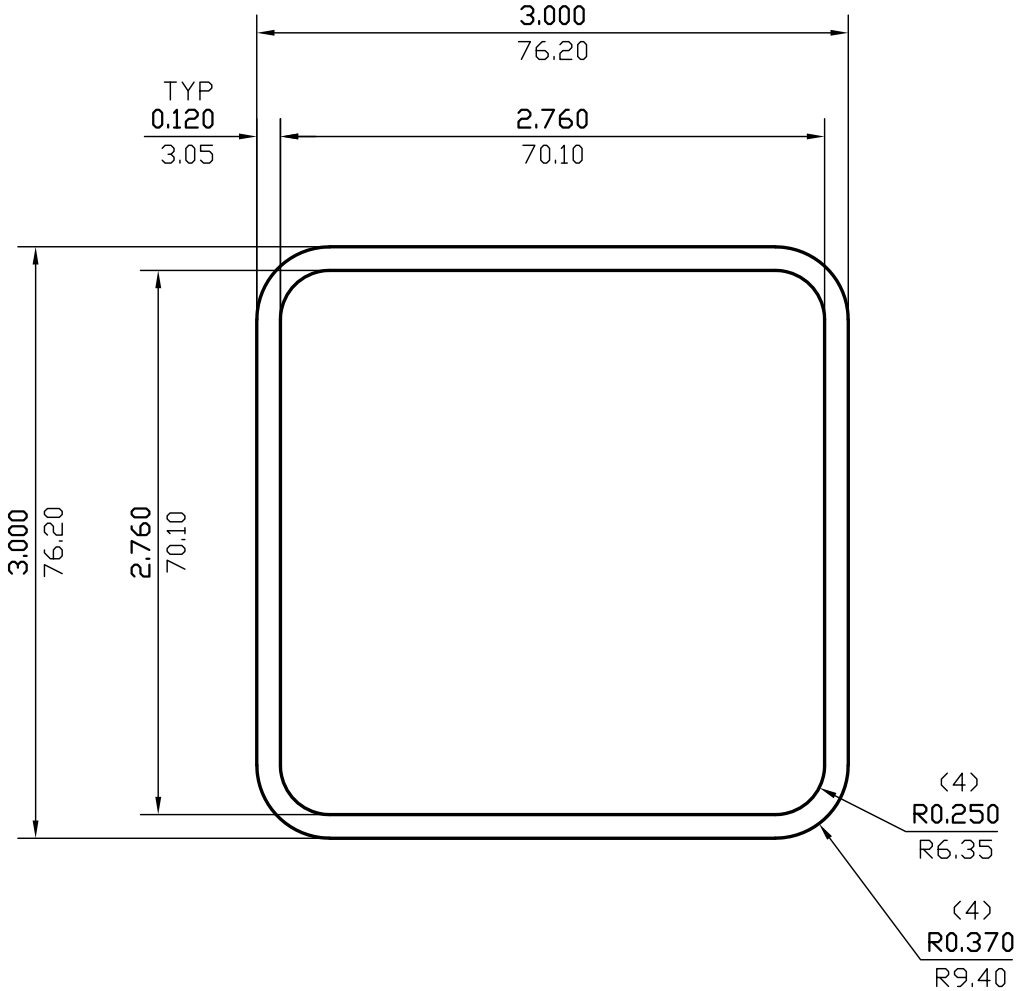

NOTE: BREAK ALL CORNERS WITH 0.015" (.38 MM) RADIUS UNLESS OTHERWISE NOTED. STANDARD TOLERANCES TO APPLY UNLESS OTHERWISE SPECIFIED.

WALL THICKNESS 0.120 (3.05) EXCEPT AS SHOWN

DATE	REV	DESCRIPTION	BY
03/13/23	1	REMOVED ALLOY	JASON
EST.AREA	1.319	IN. <sup>2</sup>	EST.AREA 850.672
			MM. <sup>2</sup>
EST.WT.	1.556	LBS/FT.	EST.WT. 2.315
			KG/M.
EST.PER.	21.976	IN.	EST.PER. 558.180
			MM.
OUT PER.	11.365	IN.	OUT PER. 288.7
			MM.
C.C.D.	3.936	IN.	C.C.D. 99.978
			MM.
FINISH	M/F		ALLOY
CKD BY	FACTOR 14	SCALE 1:1	DWN BY P.M. DATE 02/09/2009

## CAN ART

ALUMINUM EXTRUSION INC.

85 PARKSHORE DRIVE  
BRAMPTON, ONT L6T 5M1  
TEL. NO. (905) 791-1464  
FAX NO. (905) 791-9151  
WEB: www.canart.com

THIS DRAWING IS NOT NECESSARILY A COPY OF YOUR ORIGINAL. PLEASE APPROVE DIMENSIONS AND TOLERANCES INDICATED. CAN ART ASSUMES NO RESPONSIBILITY EITHER TECHNICAL OR LEGAL FOR HAVING THIS SHAPE MADE. THE CUSTOMER AGREES TO FULLY PROTECT CAN ART ALUMINUM FROM CLAIMS OF OTHERS RESULTING FROM THIS SHAPE.

SIGNED: \_\_\_\_\_ DATE: \_\_\_\_\_